

# DESIGN AND ANALYSIS OF POPPET VALVE USING COMPOSITE MATERIAL

<sup>1</sup>K.Arun, <sup>2</sup>V.Govind, <sup>3</sup>K.Shruthi, <sup>4</sup>K.Dhanush, <sup>5</sup>Ms.B.Shuthi,

<sup>1,2,3,4</sup>Student Department of Mechanical Engineering, SRI INDU COLLEGE OF ENGINEERING & TECHNOLOGY, Ibrahimpatnam, Hyderabad.

<sup>5</sup>Assistant Professor, Department of Mechanical Engineering, SRI INDU COLLEGE OF ENGINEERING & TECHNOLOGY, Ibrahimpatnam, Hyderabad.

**Abstract:** - Composite materials are replacing the materials used in various fields and are the candidate materials for future growth. Metal matrix composites are the class of composite materials finding vast applications in automotive, aircraft, defense, sports and appliance industries. The reason for this is their exciting properties like high specific strength, stiffness, hardness, wear resistance, dimensional stability and designer flexibility. The present work of Al-Sic particulate composites with 10%, 20%, 30% of Sic fabricated through stir casting process.

The main objective of this project is to analyze the exhaust valve characteristics by determining deformation, stress, frequency and heat flux. The finite element analysis is carried to compare materials AISI 4340 Steel with Al-Sic Al-Sic particulate composites with 10%, 20%, 30% of Sic. The better material for exhaust valve is determined from the results of analysis. 3D model of exhaust valve is done in Creo 6.0. Static Structural, Thermal and Modal analyses are performed in ANSYS.

\*\*\*

## I INTRODUCTION

### 1.1. INTRODUCTION

Engine valves are located in the cylinder head. The main function of the engine valves is to let air in and out of the cylinders. That air is used to help ignite the fuel which will drive the pistons up and down.

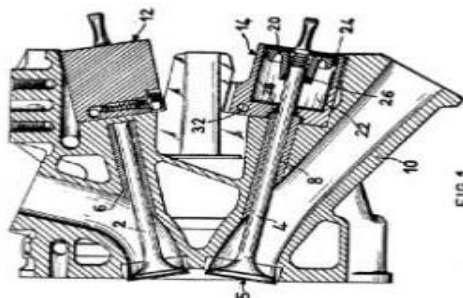

Figure 1 Schematic View of Engine

Engine valves are located in the cylinder head. The main function of the engine valves is to let air in and out of the cylinders. That air is used to help ignite the fuel which will drive the pistons up and down.

As the airflow passes various components and stages of the intake system, different properties and characteristic of the intake charge have been modified to achieve the overall goals

of the intake charge management system. The intake air filter ensures that air cleanliness is adequate, the charge air composition and oxygen content is controlled by introducing EGR to the intake air and the compressor and charge air cooler ensure that intake manifold pressure and temperature objectives are met and that intake charge density is within design limits. A few final aspects of air management are achieved after the intake charge exits the intake manifold and enters the cylinder. Valves or ports control the timing of air flow to the cylinder. Also, the passage between the intake manifold and cylinder can have a significant influence on the flow as it enters the cylinder and can be used to impart a suitable bulk motion and kinetic energy to the charge to support the mixing of air, fuel and intermediate combustion products in-cylinder.

### POPPET VALVE

A poppet valve (also called mushroom valve) is a valve typically used to control the timing and quantity of gas or vapor flow into an engine.

It consists of a hole, usually round or oval, and a tapered plug, usually a disk shape on the end of a shaft also called a valve stem. The portion of the hole where the plug meets with it is called the "seat" or "valve seat". The shaft guides the plug portion by sliding through a valve guide. In exhaust applications a pressure differential helps to seal the

valve and in intake valves a pressure differential helps open it. The poppet valve was most likely invented in 1833 by E.A.G. Young of the Newcastle and Frenchtown Railroad. Young patented his idea, but the Patent Office fire of 1836 destroyed all records of it.



Figure 2 Poppet valve & components

### INTRODUCTION TO CREO 6.0

Creo 6.0, PTC's constant, integrated 3D CAD/CAM/CAE answer, is employed by in applied science style and producing. In 1980's Dr. Samuel P. Geisberg created this code as Pro/Engineer that is taken into account because the industry's initial triple-crown constant, 3D CAD modeling code. The constant modeling approach uses parameters, dimensions, features, and relationships to capture supposed product behavior and permits style automation and therefore the improvement of style and products development processes.

### INTRODUCTION TO FEA

Finite component Analysis (FEA) was initial developed by R. Courant in 1943, UN agency used the Ritz methodology of numerical analysis and diminution of variational calculus to get approximate solutions to vibration systems.

A material or a style is stresses and analyzed for specific results employing a pc model. FEA is employed in new product style, and existing product modification. An organization that is in a position to verify a projected style may be ready to perform to the client's specifications before producing or construction. It's additionally accustomed offer a brand new service condition to the prevailing product or structure. Just in case of structural

failure, it's accustomed facilitate confirm the planning modifications to fulfill the new necessities.

### LITERATURE REVIEW

**Ch. Mani Kumar, [1]**, Intake and exhaust valves in I.C. engines are called as poppet valves. These valves are operated by valve mechanism. When these valves are exposed to the heat thermal stresses are developed so that thermal analysis is very important to predicting and preventing failures in valves. This paper aims to model and simulate the thermal analysis on poppet valves applications of 99.3cc. Modeling of the valves was done in the solidworks and thermal analysis was carried out in the ANSYS. In thermal analysis determined directional heat flux, total heat flux and temperature. Here used three materials for each valves and suggested best material for each valves on basis of thermal point of view.

**S.K. Rajesh Kanna, [2]**, In this research, valve performance has been improved by coating Al-Si alloy on the surface of mating zone of engine valve. Al-Si alloy coated valve had tested and the comparative results proved that the mechanical characteristics increased without affecting the functionality. The Al-Si coating was done on the engine valve by physical vapor deposition method in a controlled environment. As the analysis results are satisfactory, the same coating can be extended to other parts of the engines to improve the overall effectiveness of the engine.

**B Seshagiri Rao [3]**, The aim of this paper is to design an exhaust valve for a four wheeler petrol engine using theoretical calculations. Manufacturing process that is 2D drawings is drafted from the calculations and 3D model and transient thermal analysis is to be done on the exhaust valve when valve is open and closed. Analysis is done in ANSYS. Analysis will be conduct when the study state condition is attained. Study state condition is attained at 5000 cycles at the time of when valve is closed is 127.651 sec valve is opened 127.659 sec. The material used for exhaust valve is EN52 steel. We are doing material optimization by doing analysis on both materials EN52 and EN59. Static Modal analysis the exhaust valve to determine mode shapes of the valve for number of modes.

**D.B. Jani [4]**, presented a method for analysis of the thermal behavior of exhaust valve of internal combustion engine. The purpose of the analysis is to study the characteristics of exhaust valve under given thermal load and stresses. The result obtained from analysis is verified. At the design stage it is necessary to predict accurately, the behavior of exhaust valve under given load and speed. Nowadays, model analysis has become a common tool for studying the behavior of complex mechanical structures. However the analysis of extensive data sets that are obtained during model testing requires additional efforts for the development of dedicated model parameter estimation methods. The approach of the software validation results is more

convergent to the experimental results but the conditions in the ANSYS model should be as close to reality as possible to ensure acceptable accuracy. It is normal, however, to assume uniform initial conditions in all parts in mechanical simulations.

Often that is a reasonable assumption, but there are several examples of instances where non-uniform properties caused by the manufacturing processes produce significant effects on the product performance. Finite element (FE) methods represent a powerful tool for both engineering analysis and mathematical analysis. In this method attempts were made to simulate a test condition and then study the result of FEA to assess whether the design meets the requirement or not. If the simulations reveal that the design might fail, the engineer would modify the design to avoid the failure; this method was helping to avoid the design value data to test through tests of prototype. This approach was used by experienced engineers who were used to design the equipment by conventional approaches but want to avoid testing. The main objective of this paper is to carry out Finite Element Analysis (FEA) in view to predict temperature distribution across the exhaust valve. Several specific features of the original design then is modified depending upon results, in view to reduce temperature of the exhaust valve. This paper also includes drawing 3D model of the valve, meshing and analysis by using ANSYS.

**Hemendra Kumar Srivastva [5]**, In this work, an effort has been designed to raise the reliability of engine using Al-SiC composites with other alternative materials for the engine valve guides. Aluminum matrix composites have found the most suitable inside automotive, aerospace and aircraft industries and contain the greatest promise for future year's growth. The finite element analysis of the Al-SiC composite with Titanium alloy (Ti-834), Copper Nickel Silicon alloys (CuNi3Si), and aluminum bronze alloy as an alternative material for engine valve guide was done using Ansys 13.0 software. The stress analysis of engine valve guide under the different pressure and temperature is considered, the pressure is taken as from 10 MPa to 100 MPa with different temperatures varying from 600°C to 650°C. The temperature, principal stress and principal strain distribution on the entire surface area of the engine valve guide were obtained. The stresses were observed to be well below the permitted stress for all the materials but the Al-SiC composites found the most suitable one. Valve guide is modeled in pro-engineer software and analysis is carried out in Ansys 13.0. The deformations and stresses induced due to structural and thermal loading is illustrated and discussed.

**Kuldeep Shakya [6]**, dealt with the analysis of thermal stress developed in a valve due to high pressure within the combustion chamber at high temperature situations. For modelling Solidwork is to be utilized and to optimize the Poppet valve ANSYS will be utilized as the tool. Steady State thermal analyses are to be performed on the valve based on

fillet radius at 3mm, 6mm and 10mm and Chamfer at 2mm, 4 mm and 6 mm at 45° angle. Maximum thermal stresses found 24.783 MPa at 6 mm chamfer at 45° angle. Hence it is clear that 6 mm fillet radius of poppet valve is best and safe for designing of I.C. Engine inlet and outlet valve.

**Dr. Hiregoudar Yerrenagoudaru [7]**, To generate air swirl inside a direct ignition diesel engine combustion chamber an attempt is made to modify some possible changes in an inlet valves without disturbing the properties of valve material, which ensures an improved combustion and a noticeable improvement in emission levels at its exhaust gases. In order to select better and most suitable modifications in practicality the simulation through CFD is the most precise and accurate way of selecting the optimum modification in inlet poppet valves.

**S. M. Chabru [8]**, Poppet valve is an important component of the engine. The pair of inlet and exhaust valve is called as poppet valves or Mushroom valve. Exhaust valve is used to bypass the burnt gases out from the engine through exhaust port after power stroke. As it belongs to continuously come into very high temperature and pressure regions so that there is more possibility of exhaust valve failure hence we need to take care of exhaust valve we trying to optimize the result by varying geometrical parameters of the valve like fillet radius, chamfer angle, Diameter of the valve head.

**Ukawa, H. [9]**, Improvements in the engine performance, efficiency, scavenging, and emission characteristics of a modified two-stroke-cycle engine with the poppet valves and gaseous-fuel direct-injection system are described. In previous papers, SAE 901664 and 920180, in which the scavenging characteristics were mainly investigated, the modified two-stroke-cycle engine was based on a production four-stroke-cycle engine. The base engine intake valve was used as scavenging valve, with a shroud installed for preventing the short-circuiting charge loss. As shown in the previous results, considerable improvement of the scavenging efficiency was obtained. While a gasoline fuel carburetion system was used in the earlier engine, the present engine used a propane gas direct-injection system, with the purposes of further decreasing fuel short-circuiting loss and also improving combustion preparation characteristics in terms of fuel atomization, vaporization and mixing with air.

### III. METHODOLOGY

The alloy of aluminum and silicon proved to have better hardness, crushing strength, higher wear resistance, etc (Buytoz, 2006). So in this research, Al-SiC composites have been used by varying the percentage of silicon from 0 to 75 %. In the standard engine valve, coating of 0.2 mm will be done using vapor deposition method over the entire surface. The ratio of Al-Si composition in the alloy has been optimally identified by

conducting various simulations on the computer using Ansys software. In this project, finite element technique is used identify the mechanical properties and characteristics of the Al-Si composites. The output obtained is investigated to identify the best optimal coating for four stroke IC engine valves to improve its life and wear resistance. The finite element analysis of engine valve was done along with its valve guide to correlate the relation between the valve and valve guide. For analysis, geometric modeling of the valve had done using Creo software as a single part. Then the model had converted to a neutral format and then imported to the Ansys software for analysis. As the valve is a symmetrical object, axis symmetry analysis had been carried out to reduce the computational. Major boundary conditions considered for the analysis are the temperature, pressure and degrees of freedom. The ranges of the boundary condition parameters are as follows,

(i) Temperature boundary conditions:  $650^{\circ}\text{C}$

(ii) Pressure boundary conditions:

Pressure on engine valve guide: 10MPa

(iii) Displacement boundary conditions:

Rotational degrees of freedom:  $0dx=dy=0; dz=1$

### 3.1: MATERIAL PROPERTIES

Material	Density ( $\text{Kg/m}^3$ )	Young's Modulus (GPa)	Poisson's Ratio	Thermal Conductivity (W/m-K)
AISI 4340	7850	192	0.29	44.5
Al-Sic (10%)	2750	77.4	0.33	173
Al-Sic (20%)	2820	86	0.32	168
Al-Sic (30%)	2940	92	0.31	164

### IV ANALYSIS OF ENGINE VALVE

#### STRUCTURAL ANALYSIS OF ENGINE VALVE

##### MATERIAL-AISI 4340

Save Creo Model as .iges format

→ → Ansys → Workbench → Select analysis system → static structural → double click

Double click → edit material

→ → Select geometry → right click → import geometry → select browse → open part → ok

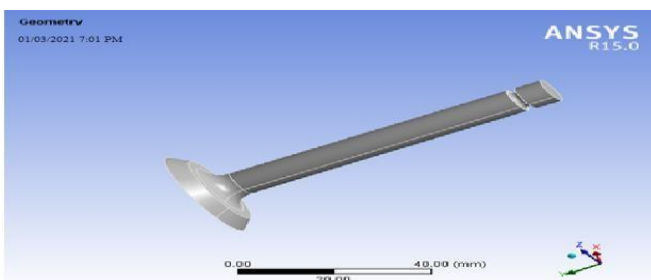

Figure 3: Imported model from Creo

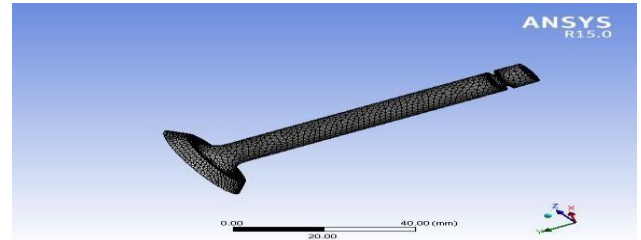

Figure 4: Meshed model of valve

##### MATERIAL-Al+Sic(10%)

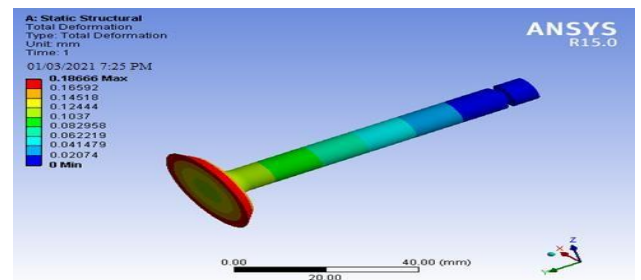

Figure 5: Total Deformation of valve using Al+Sic(10%)

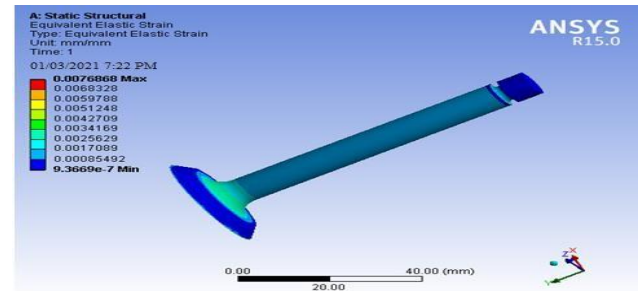

Figure 6: Strain of valve using Al+Sic(10%)

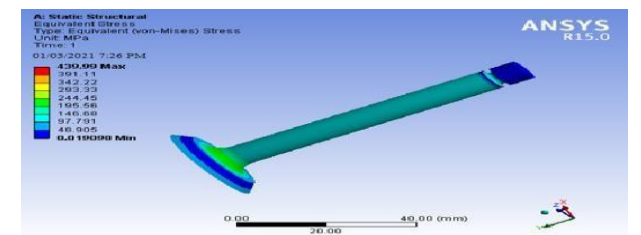

Figure 7: Stress of valve using Al+Sic(10%)

##### MATERIAL-Al+Sic(20%)

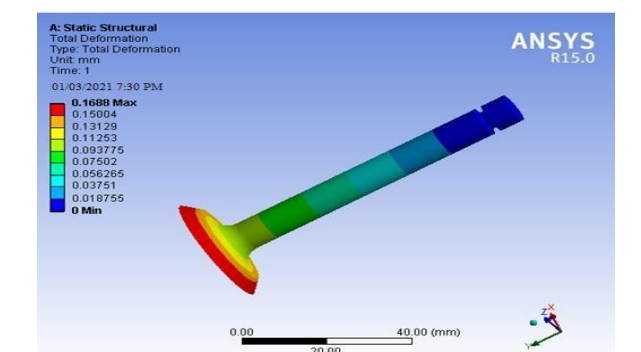

Figure 8: Total Deformation of valve using Al+Sic(20%)

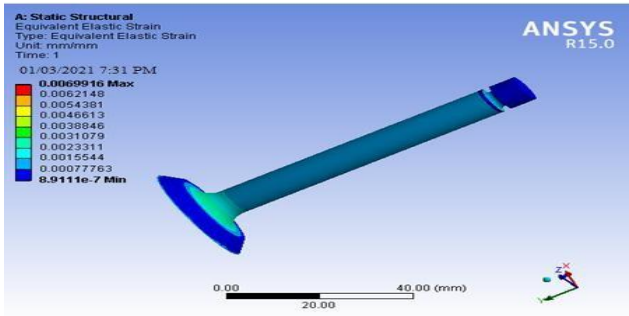

Figure9:Fig:StrainofvalveusingAl+Sic(20%)

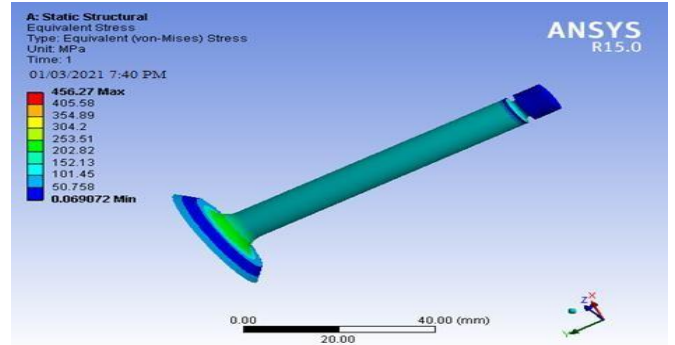

Figure13:StressofvalveusingAl+Sic(30%)

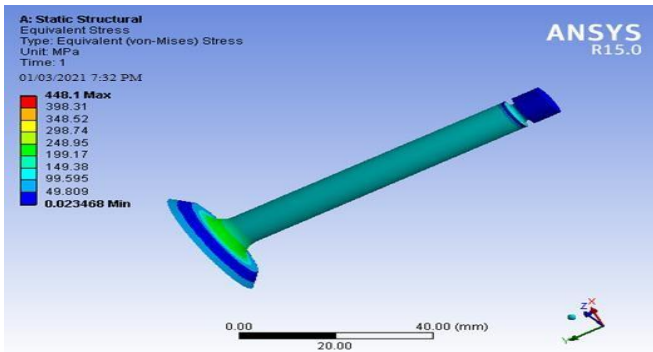

Figure10:StressofvalveusingAl+Sic(20%)

4.5 MODAL ANALYSIS

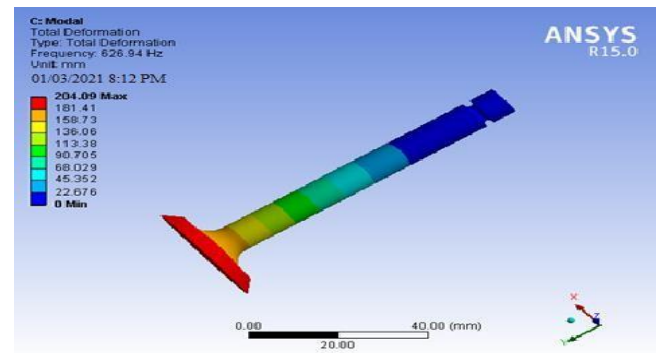

Figure14:Totaldeformationatmode1usingAISI4340

4.4 MATERIAL -Al+Sic (30%)

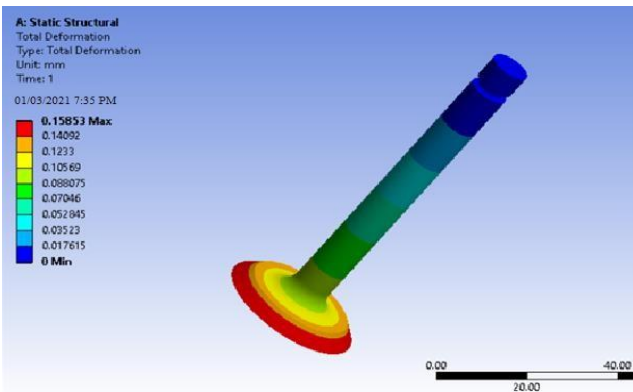

Figure11:TotalDeformationofvalveusingAl+Sic(30%)

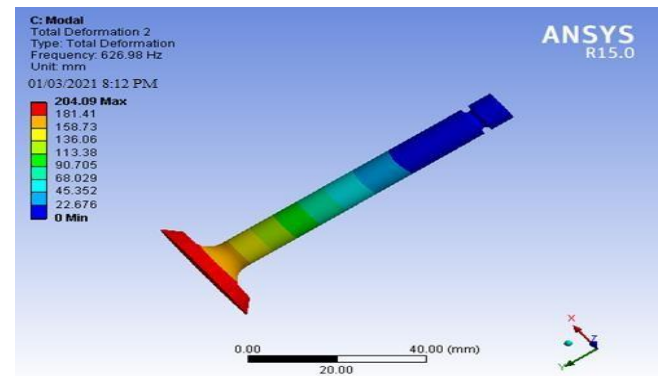

Figure15:Totaldeformationatmode2usingAISI4340

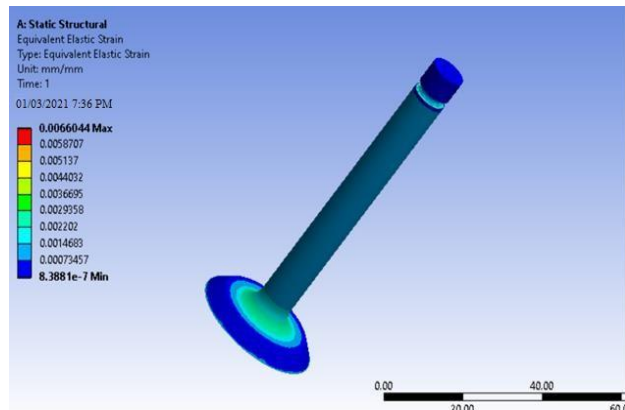

Figure12:StrainofvalveusingAl+Sic(30%)

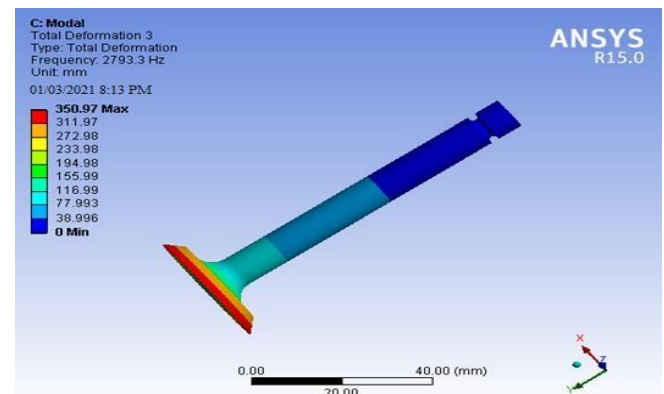

Figure16:Totaldeformationatmode3usingAISI4340

**VRESULTS&DISCUSSIONS**

**Structural analysis**

The results analyzed from analysis are deformation, stress and strain in Structural analysis.

MATERIAL	DEFORMATION (mm)	STRAIN	STRESS (MPa)
AISI 4340	0.076673	0.0032309	472.74
Al+Sic (10%)	0.18666	0.0076868	439.99
Al+Sic (20%)	0.1688	0.0069916	448.1
Al+Sic (30%)	0.15853	0.006604	456.27

Table 5.1: Results from Structural analysis

By observing above results, the deformations are less when AISI 4340 Steel is used when compared with that of Al+Sic MMC's. The stresses are less when Al+Sic MMC's are used as compared with AISI 4340 Steel. The stresses are increasing when AISI 4340 Steel is used as compared with, by about 7% for Al+Sic10%, by about 5% for Al+Sic 20%, by about 4% for Al+Sic30%.

The stresses are increasing by increasing the Silicon percentage in MMC. The stresses are increasing when Al+Sic30% is used as compared with, by about 3.5% for Al+Sic10%, by about 1.8% for Al+Sic20%.

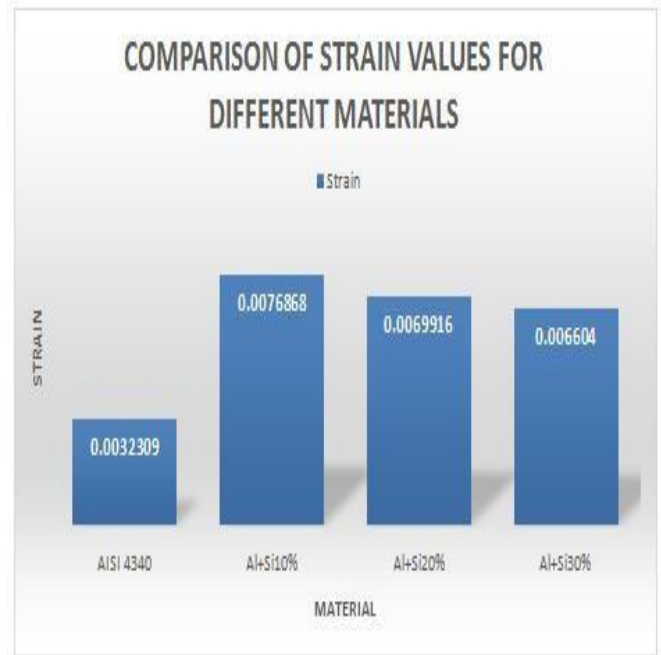

Figure 19: COMPARISON OF STRAIN VALUES FOR DIFFERENT MATERIALS

**THERMAL ANALYSIS**

The results analyzed from thermal analysis are temperature distribution and heat flux.



Figure 17: COMPARISON OF DEFORMATION VALUES FOR DIFFERENT MATERIALS

MATERIAL	TEMPERATURE (Min) (K)	HEAT FLUX (W/mm <sup>2</sup> )
AISI 4340	477.23	0.84845
Al+Sic (10%)	683.75	1.4805
Al+Sic (20%)	648.8	1.4677
Al+Sic (30%)	644.65	1.4572

Table 5.2: Results from Thermal analysis

By observing above results, the temperatures are less when AISI 4340 Steel is used when compared with that of Al+Sic MMC's. The heat flux values are less when AISI 4340 Steel is used when compared with that of Al+Sic MMC's. The heat flux values are decreasing when AISI 4340 Steel is used as compared with, by about 43% for Al+Sic10%, by about 42% for Al+Sic20%, by about 41% for Al+Sic30%.

The heat flux values are decreasing by increasing the Silicon percentage in MMC. The heat flux values are decreasing when Al+Sic30% is used as compared with, by about 1.6% for Al+Sic10%, by about 0.7% for Al+Sic20%.

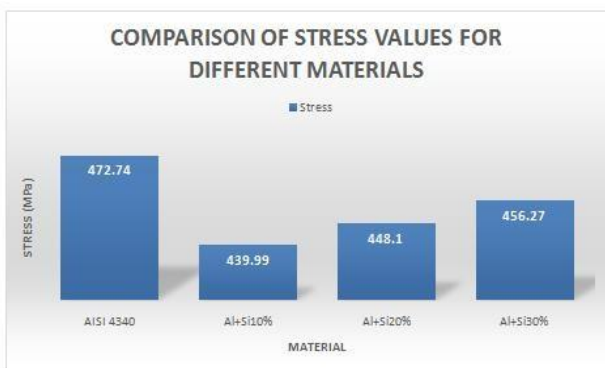
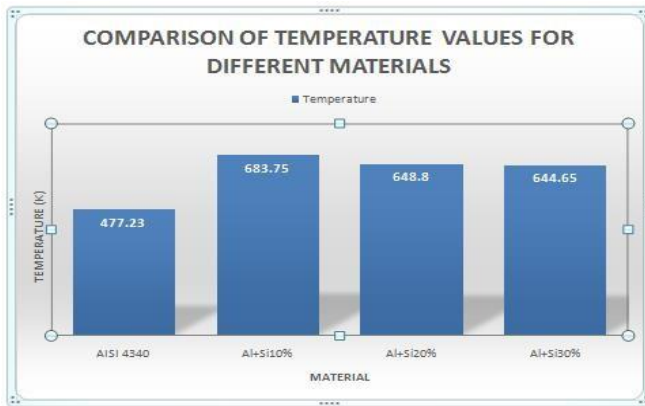

Figure 18: COMPARISON OF STRESS VALUES FOR DIFFERENT MATERIALS



**Figure20: COMPARISON OF TEMPERATURE VALUES FOR DIFFERENT MATERIALS**

**MODAL ANALYSIS**

MATERIAL	DEFORMATION (mm)		
	Mode 1	Mode 2	Mode 3
AISI 4340	204.09	204.09	350.97
Al+Si (10%)	344.84	344.84	592.98
Al+Si (20%)	340.52	340.52	585.57
Al+Si (30%)	333.5	333.49	573.49

**Table5.3: Deformation Results from Modal Analysis**



**Figure21: COMPARISON OF DEFORMATION VALUES FOR DIFFERENT MATERIALS**

**VICONCLUSION**

Static Structural, Thermal and Modal analyses are performed on the exhaust valve by comparing AISI 4340 Steel with Al+SiCMMC's. The Al+SiCMMC's are considered by varying the Silicon percentage 10%, 20% and 30%.

By observing Static Structural analysis results, the deformations are less when AISI 4340 Steel is used when compared with that of Al+SiCMMC's. The stresses are less when Al+SiCMMC's are used as compared with AISI 4340 Steel. The stresses are increasing by increasing the Silicon percentage in MMC.

By observing thermal analysis results, the temperatures are less when AISI 4340 Steel is used when compared with that of Al+SiC MMC's. The heat flux values are less when AISI 4340 Steel is used when compared with that of Al+SiCMMC's. The heat flux values are decreasing by increasing the Silicon percentage in MMC.

By observing modal analysis results, the deformations are less when AISI 4340 Steel is used when compared with that of Al+SiCMMC's. The frequencies are more when Al+SiCMMC's are used as compared with AISI 4340 Steel. The frequencies are increasing by increasing the Silicon percentage in MMC.

So it can be concluded that using Al+SiCMMC's for exhaust valve is better than steel as per the results and also the weight of the valve is more when Steel is used due to its high density. The results are favorable when Silicon percentage is less in the MMC.

**REFERENCES**

1. Ch. Mani Kumar and P. Rajendra Babu, Design & Thermal Analysis of I.C. Engine Poppet Valves using Solidworks and FEA, International Research Journal of Engineering and Technology (IRJET) e-ISSN: 2395 -0056 Volume: 04 Issue: 03 | Mar -2017 [www.irjet.net](http://www.irjet.net) p-ISSN: 2395-0072.
2. S.K. Rajesh Kanna\*, R. Ragu, P.S. Rajeswaran and Muthuvignesh, Performance evaluation using FEA on Al-Si coated engine valve, IJCRAR ISSN: 2347-3215 Volume 3 Number 8 (August-2015) pp. 67-72 [www.ijcrar.com](http://www.ijcrar.com).
3. B Seshagiri Rao and D Gopi Chandu, petrol engine exhaust valve design, Analysis and manufacturing processes ISSN 2278 – 0149 [www.ijmerr.com](http://www.ijmerr.com) Vol. 3, No. 4, October, 2014 ©2014IJMERR. All Rights Reserved.
4. D.B. Jani, M.C. Gohil, Analysis for poppet valve of a diesel engine, "Recent advances in manufacturing" (RAM-2010),
5. Hemendra Kumar Srivastva, Arurendra Singh Chauhan, Manmohan Kushwaha, Comparative Study of Different Materials with Al-SiC for Engine Valve Guide by Using FEM, World Journal of Engineering and Technology, 2016, 4, 238-251 Published Online May 2016 in SciRes.
6. Kuldeep Shakya, P.S. Dhakar, Steady State Thermal Analysis of I.C. Engine Poppet Valve Using ANSYS, International Journal of Technical Innovation in Modern Engineering & Science (IJTIMES) Impact Factor: 5.22 (SJIF-2017), e-ISSN: 2455-2585 Volume 4, Issue 6, June-2018.
7. Dr. Hiregoudar Yerrennagoudaru, Shiva Prasad Desai, Mallikarjuna. A, Experimental Investigation on Modification of Inlet poppet valve of single cylinder Direct Ignition Four stroke Diesel Engine, International Journal of Latest Engineering Research and Applications (IJLERA) ISSN: 2455-7137 Volume – 01, Issue – 03, June – 2016, PP –43-53.



8. S. M. Chabru, Prof. P. S. Kulkarni, Design and Analysis of IC Engine Poppet Valve with Varied Geometrical Parameters, International Journal of Engineering Research & Technology (IJERT) ISSN: 2278-0181 IJERTV8IS070181, Vol. 8 Issue 07, July-2019.
9. Ukawa, H., Nakano, M., and Sato, K., "A Two-Stroke Cycle Engine with Poppet Valves in the Cylinder Head - Part III: An Application of Gaseous Fuel Direct Injection System," SAE Technical Paper 930983, 1993, <https://doi.org/10.4271/930983>.
10. Vidyadhar. C. Kale, Sagar. S. Deshpande, Design and Analysis of Poppet Engine Valve for Enhanced Mechanical Properties with Varied Geometric Parameters and Materials, International Journal of Engineering Sciences & Research Technology, 3(11): November, 2014, ISSN: 2277-9655